

A Simplified Approach to the Use of Reflected Light Microscopes

by F. Restivo

This article is a compilation of information on optical microscopy. It has been extracted from sales literature and publications as listed in the bibliography. The only purpose of this effort is to provide a reasonably uncomplicated understanding of reflected light microscopes. It is primarily oriented to laboratory personnel and those interested in the use and care of such instruments.

WHAT'S INSIDE OF A REFLECTED LIGHT MICROSCOPE?

A simple traditional reflected light microscope includes an objective, a vertical illuminator with a light source, and an eyepiece.

Objective

The objective acts like a small projection lens, but instead of projecting an image onto a screen, it projects an enlarged primary image of the object up near the top of the microscope tube. This primary image is formed in the air and is called an "aerial image" or "real image".

Eyepiece

The eyepiece acts like a magnifier. The principle difference being that it is used to magnify an "aerial image" instead of an actual object. The microscope attains its magnification in two stages. First by the objective, secondly by the eyepiece. The final magnification is the product of the two stages except when zoom systems are employed. The final image commonly referred to as the "virtual image" is formed on the retina of the eye, a projection plane, or a film plane.

Vertical Illuminator

The vertical illuminator is located between the objective and the eyepiece. It is the means by which the specimen is illuminated. It consists of a light source with a collecting or condensing lens, an aperture iris (diaphragm) and a field iris (diaphragm). It also contains a reflector, which can be a prism, a plain glass, or a Gauss or half mirror. The reflector is mounted so that the bundles of light from the source will deflect at 90°.

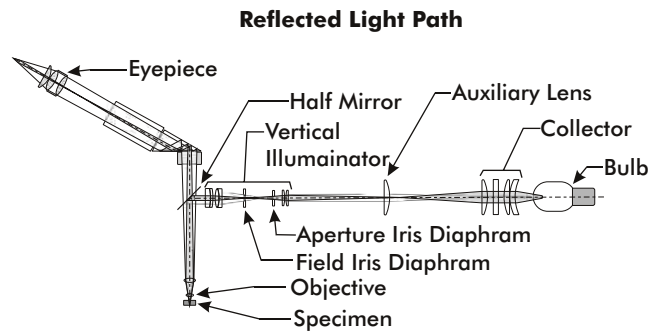

LENSES

What is a Lens?

A lens is a piece of glass or other transparent substance bounded by two surfaces of different curvature—one surface is general spherical while the other is usually flat, spherical, or inverse spherical. By use of the lens, rays or light may be made to converge or to diverge. Any device which can be used for concentrating or dispersing radiation by means of a refraction can be called a lens.

Kinds of Lenses

Positive lenses are thicker in the middle than at the edge. They cause parallel light rays to converge to a focal point.

Negative lenses are thinner in the middle than at the edge. They cause parallel light rays to divert from a virtual focal point.

The six common lens classifications are as follows.

- Convex-Convex or Biconvex
- Plano-Convex
- Convex-Concave
- Concave-Concave or Biconcave
- Plano-Concave
- Concave-Convex

Why is Glass Usually Most Suitable for Lenses?

Glass produced with modern techniques has great strength as well as hardness. Furthermore, it can be polished down to a smoothness unequalled by most other materials. Unlike most metals, it will not rust, shrink, or warp. It can be made highly resistant to thermal and physical shock. It can be molded into diverse shapes and retain these shapes over long periods of time.

Glass has the following desirable properties.

- Resistance to heat
- Chemical stability
- Smoothness of surface
- Retention of shape
- Proper dimensions
- Resistance to physical shock
- Transparency (light transmission)
- Toughness
- Surface configuration
- Free of distortion
- Proper refraction values

Lens Terminology (Types of Glass Used)

Glass is normally a transparent substance made by fusing one or more of the oxides of silicon, boron, or phosphorus with certain basic oxides. Rapid cooling prevents crystallization. The principle general types are as follows.

Borosilicate Glass

A tough optical and thermal glass (pyrex)

Crown Glass

Ordinary uncolored green glass

Flint Glass

Hard optical sodium-silicate (low refraction)

Ground Glass

Soft, optical lead-oxide (high refraction)

Lime Glass

Made of lime and soda (window plate and container)

Milk Glass

Opaque, contains cyrolite

Optical Glass

High quality, specially compounded for use in lenses; it must be chemically homogeneous and must be free from physical imperfections; it must be available in a wide range of refractive indices and dispersion

OBJECTIVES

As the power increases, the working distance is shorter.

The higher the power, the shorter the distance

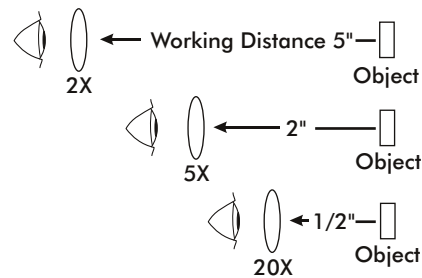

This illustrates the rule that the working distance decreases as the power of the lens increases. An object must be brought to within one-half inch of a 20X lens to be seen clearly.

As the power increases, the lens diameter decreases.

As the power increases, the field of view decreases.

The higher the power, smaller the lens

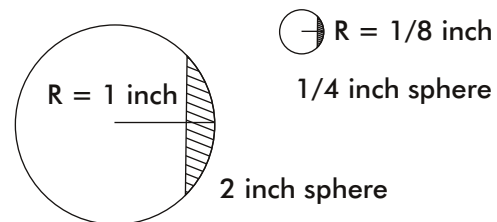

Lens surfaces are sections of spheres. So picture the lens as being sliced from a solid ball of glass. The higher the magnifying power of the lens, the sharper must be the curvature. Therefore the ball, and consequently the lens, becomes smaller.

As the power increases, the depth of field decreases.

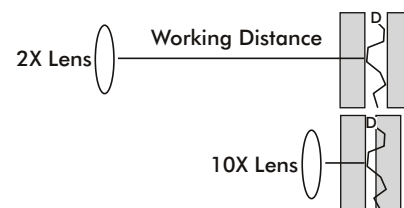

In this simplified diagram, D stands for depth of field. Notice that with the 2X lens, D is considerable—all of the gear tooth is viewed clearly at once. With the higher power (10X), D is much less, and only a portion of the gear tooth is in focus at a time. Field depth and working distance decrease as power increases.

Achromats

Spherical and chromate correction is made for the middle portion of the spectrum. Must be used with yellow-green filters for best results. Corrected chromatically for two colors; spherically for one color.

Fluorites or Semi-Apochromats

Better chromatic correction through the use of fluorite. Improved color correction and increased resolving power due to low refractive index and more favorable dispersion of fluorite. Corrected chromatically for two colors; spherically for two colors.

Apochromats

Have an increased number of lens elements, including fluorite. Corrected to the highest degree chromatically for three colors; spherically for two.

Flat Field Objectives

Flat Field Objectives are without a doubt the most interesting advancement in optical design during the last decade. Through the use of additional lens elements, curvature of field has been eliminated. The field of view has been expanded by a factor of 4 times. When used with the proper wide field eyepieces, the image quality is excellent out to the very edge of the field.

A very significant advancement in flat field correction is the area over which the curvature is kept within the limits of the depth of field. Finely made flat field objectives are designed to permit a large aerial image. This means that the field of view is no longer limited by the objective correction or the diameter of the ocular, but by the interpupillary distance of the microscopist. Therefore, to take full advantage of the extreme wide angle field, binocular bodies with extra wide prisms are necessary.

NUMERICAL APERTURE (N.A.)

Working Distance and N.A.

The extreme light pencils admitted onto a specimen depend upon its working distance. Longer working distance, smaller aperture angle, less light pencils admitted.

Working Distance and Numerical Aperture

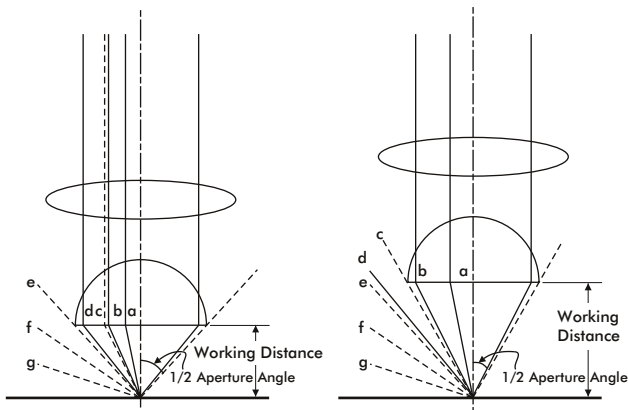

Dry and Immersion Objectives and N.A.

The refractive index or bending power of the medium between specimen and objective through which the light passes is maximum 1.00 for air and maximum 1.51 for oil. It can be seen that an oil immersion objective will always have a higher resolving power than a dry lens of equal focus because of the higher refractive index of oil.

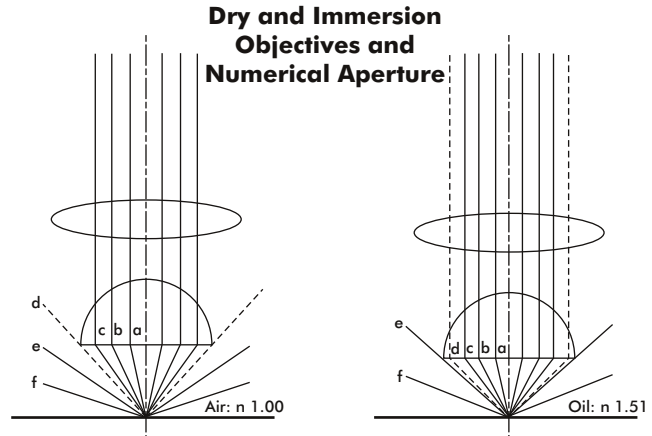

EYEPIECES

Four types of eyepiece systems are most widely used today.

Huygenian

The Huygenian type consists of two simple lenses with a field diaphragm located between the field lens and the eyelens. It is basically a low magnification eyepiece.

Ramsden or Orthoscopic

The Ramsden or Orthoscopic type consists of four lens elements with the field diaphragm located below them. It is normally used for medium-power investigations.

Compensating

The Compensating type has the highest correction for chromatic differences of magnification and curvature of field. It is recommended for high magnification and for color photomicrography with apochromatic objectives.

Wide Angle

The Wide Angle High Eyepoint type consists of many lens elements, is designed to focus the specimen image a longer distance from its exit pupil, thus permitting comfortable use of spectacles. This feature together with the large lens diameter render this eyepiece the most accepted in today's modern instrumentation, especially when used with flat field objectives.

VERTICAL ILLUMINATORS

The rays of light leaving the field iris strike the prism, plain glass, or half mirror, and are reflected at a right angle through the objective.

Prism Reflector

The Prism Reflector can only be used with low power objectives (those with large front lens diameters). Although it transmits 100% of the available light, its image would physically interfere with the path of light in a fairly high-power objective. With this reflector, one half of the objective acts as an illuminating system while the other half serves as a magnifier and image forming system.

This condition brings about unbalance resolution (a reduced rendition of fine details).

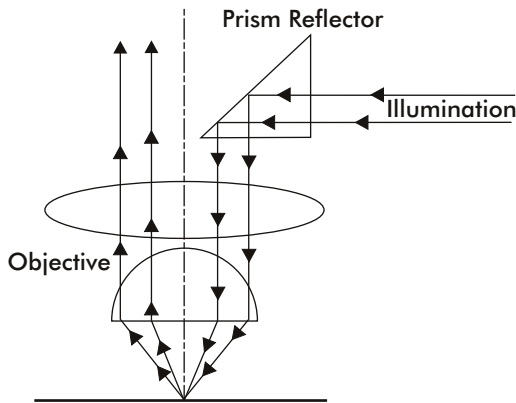

Plain Glass Reflector

The Plain Glass Reflector is a very thin glass plate inclined at 45° thus reflecting part of the illuminating rays at 90° through the objective and onto the specimen. The illuminated specimen with its characteristic structure can then be observed because the light that returns from the specimen passes through the thin glass plate without obstruction. In this system the objective acts first as an illuminator and then as an image forming system. When it is properly centered, plain axial illumination is the result, as no shadows are formed—even from specimens with relief structures. This reflector can be used with any objective. A disadvantage is the loss of light transmission through the glass.

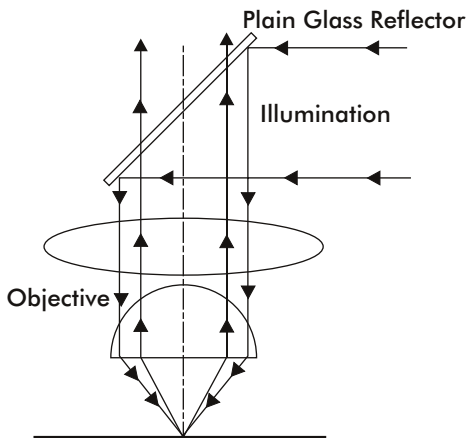

Half Mirror Reflector

The Gauss or Half Mirror Reflector is a totally reflecting surface with a thin clear coated glass center. The clear

coated center is ellipsoid in shape so that a round bundle of rays can be reflected when it is mounted at a 45° angle. This particular type of reflector is one of the most universally accepted for all kinds of illumination. The coated air to glass surfaces of the clear center and the 100% reflectance of the mirror render it most adaptable for brightfield and darkfield illumination.

The rays of light from the reflector pass through the objective or around the outside of its barrel depending upon the type of illumination, and strike the surface of the specimen. The rays reflected from the specimen image then pass back through the objective lenses and through the reflector to the eyepiece. The enlarged aerial image is magnified a second time and relayed to the eye, a viewing plane, or a photographic plane.

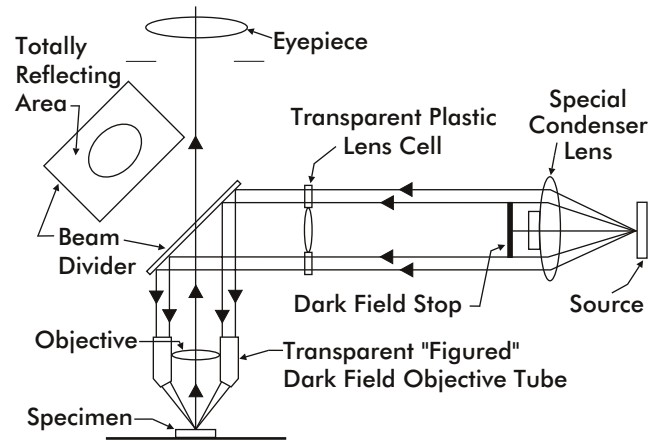

TYPES OF ILLUMINATION

Brightfield Illumination

Brightfield Illumination occurs when the reflecting surfaces, which are perpendicular to the axis of the objective, appear bright. It is the first form of and most widely used type of illumination.

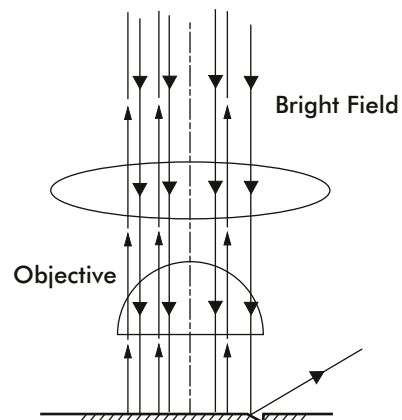

Darkfield Illumination

Darkfield Illumination occurs when the rays of light striking the reflecting surfaces do not enter the objective but are reflected at an acute angle. Ever-so-slight irregularities in the surface reflect light at angles, which will enter the objective. In this mode of

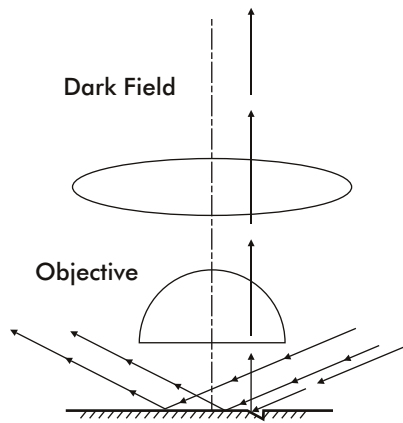

illumination, the light rays are directed around the objective lenses from 360° , and not through them. The most minute deviation from an absolutely plain, mirror-like surface will show up bright on a black background.

Oblique Illumination

Oblique Illumination occurs when the rays of light are decentered. This causes them to strike the reflecting surface from one direction at an angle. The result is a relief structure created by shadows. Oblique rays are normally caused by decentering the aperture iris or the light source.

Polarized Light

Polarized Light occurs (in a brightfield system) when a polarizer is placed in the optical path between the light source and the objective, and is oriented to allow the passage of the component vibration in a direction normal to the plane of this illustration.

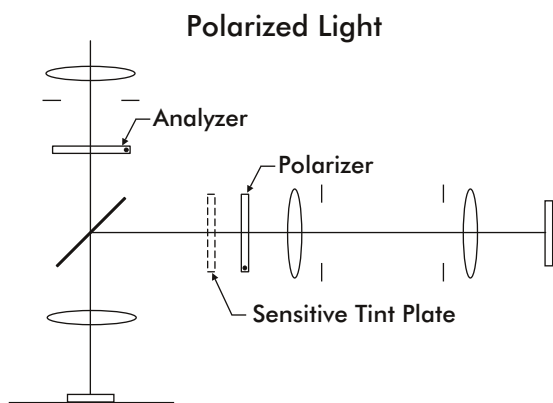

The analyzer is inserted into the visual system between the vertical illuminator and the eyepiece. It is oriented to pass the component vibrating in a direction parallel to the plane of the illustration (at right angles). Thus, the polarizer and analyzer are crossed, causing extinction. Under these conditions, the field of view appears dark. By rotating a specimen through 360° , one may observe the reaction of its surface. For the analysis of metals it is used to determine isotropic and anisotropic substances. If the specimen is rotated and

no change in the reflected image occurs, it is isotropic. If, however, substances in the specimen vary from dark to bright as it is rotated, they are anisotropic. Polycrystalline anisotropic metals (those that have different optical characteristics in different crystallographic directions) are best examined with polarized light. Antimony, Arsenic, Beryllium, Bismuth, Cadmium Magnesium, Tellurium, Tin, Titanium, Uranium, Zinc, and Zirconium are all known to react.

Sensitive Tint

Sensitive Tint, another important application of polarized light, is the study of weak bi-refringence. This is achieved by placing a special retardation plate (crystal-quartz) into the optical path with the polarizer and analyzer. Studies of this kind are accomplished by observing any change in the magenta tint as the specimen is rotated. Sensitive tint has been used to detect pores in commercial graphite and to determine the orientation of grains. Small structural differences that are not apparent in brightfield or polarized light can usually be observed with sensitive tint.

Phase Contrast

Phase Contrast occurs in a brightfield system when an illumination annulus plate (opaque with a clear annular center) is inserted in the plane of the Aperture Iris. A relay lens then forms an image at a point beyond the vertical illuminator. The phase annulus plate (located between the vertical illuminator and the eyepiece) is a clear glass onto which two separate materials have been vacuum coated over the annular area. One of the materials is a semi-transmitted metallic film that is designed to reduce the transmission of the annulus. The other material is designed to introduce an optical path difference of $1/4$ wavelength between the light through the annulus and any light through the uncoated glass area. Thus, the arrival of light at the eye will be $1/4$ wavelength out of phase. If an opaque specimen has minute elevated or depressed areas, normal methods will show only the grain boundaries. Phase contrast may render these minute height differences as shades of gray.

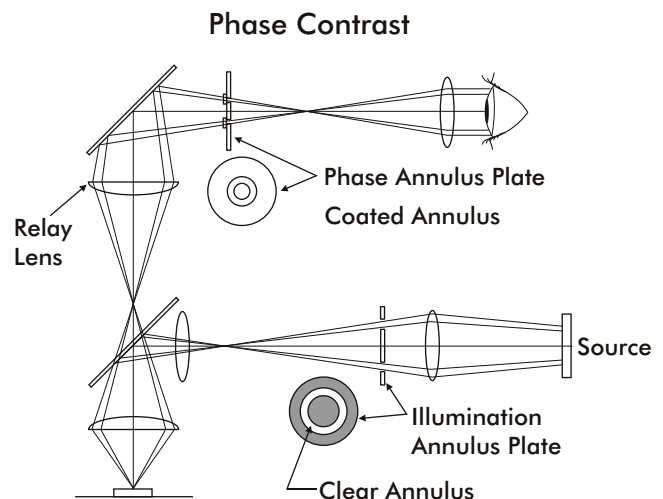

Differential Interference Contrast

Differential Interference Contrast after Nomarski occurs when in a brightfield system, with polarized light, a wollaston prism is inserted between the objective and the vertical illuminator. A ray of light emitted from the light source is linearly polarized after it passes through the polarizer. It enters the wollaston prism and is divided into two rays of linearly polarized light.

In order to equalize the intensities of the rays and to maximize contrast of the interference fringes, the prism must be placed with its principle axis 45° with respect to the direction of vibration of the linearly polarized light. Also, to avoid glare, this prism is slightly inclined toward the optical axis of the microscope.

The two divided rays intersect at a point on the plane of fringe localization that is calculated to coincide with the rear focal plane of the objective. They then pass through the objective, become parallel to each other with a slight lateral separation, and impinge on the specimen. They are reflected back and are focused on the plane of localization with the aid of the objective and are recombined by the wollaston prism. These recombined rays pass through the analyzer at a retardation equal to twice the difference in height where the two rays were reflected.

This system is superior to phase contrast in reflected light studies for the following reasons.

1. Does not cause halos.
2. Interference colors may be varied to suit any object detail from darkfield to brightfield.
3. Interference colors can be seen in proportion with the gradient path differences of the specimen.
4. Fully utilizes the objective N.A. resulting in exceptional image brightness and resolution.

Differential Interference Contrast

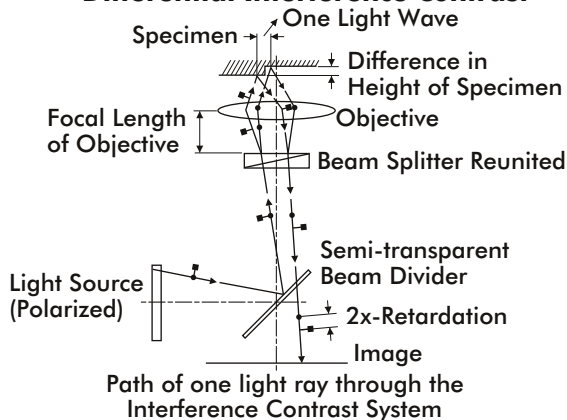

OPTICAL PRINCIPLES AND DEFECTS

Spherical Aberration

The microscope should magnify and resolve fine details in the structure of a specimen. Consequently,

good spherical and chromatic correction is essential as well as good resolving power. It is generally known that the image of an object formed by a single lens is not without defects such as spherical and chromatic aberration. The light rays that pass through a single lens from a given point do not have a common focal point. The marginal rays passing through the lens come to focus sooner than the central rays. This defect is called spherical aberration and is due to the curvature of the lens. The effect is a dull gray image.

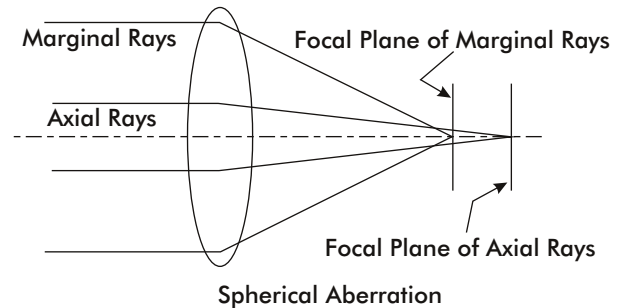

Chromatic Aberration

Unfiltered white light—regardless of its source—consists of light bundles of various wavelengths (colors); from blue (4000°A) to red (7000°A), with green at approximately (5700°A). The light is refracted to various light bundles when passing through a lens with each color coming to focus at a different point. This condition is called chromatic aberration and, along with spherical aberration, must be corrected or rendition of fine details would be hopeless. Chromatic aberration introduces color fringes so that the image is fuzzy and colors are changed. These two defects are corrected to various degrees in objectives, which, in turn, are classified by their respective correction in achromat, fluorite, and apochromat objectives and, of course, the new breed of objectives that are called "flat field".

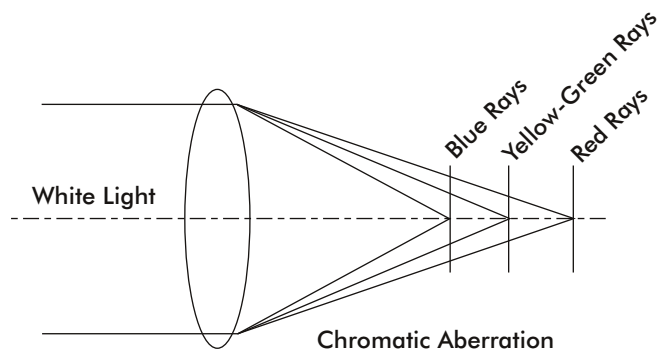

Coma, Astigmatism, and Curvature of Field

Still other aberrations known as Coma, Astigmatism, and Curvature of Field contribute to grayness and lack of detail in the outer portion of images. Unfortunately the various lens aberrations seldom exist

independently. Corrections for lens aberrations are achieved by various means. Single lens elements made from different kinds of glass are combined to form a single compound lens—as in the case of the doublet and the triplet. One element will be of crown glass, another of flint glass. One element may be positive in structure, the other negative to offset the aberrations of one another. Sometimes a diaphragm in the lens is a means of providing correction. Lens designers know what type of an image will be produced by a lens with given physical properties. By properly arranging certain kinds of lenses in series they can correct for the aberrations (to a controlled degree). Curvature of field, which is usually prevalent in the higher-power lenses, has been practically eliminated by flat field objectives.

To properly align a microscope one should start at the light source. Let us then follow the path of light through the optical system in the microscope.

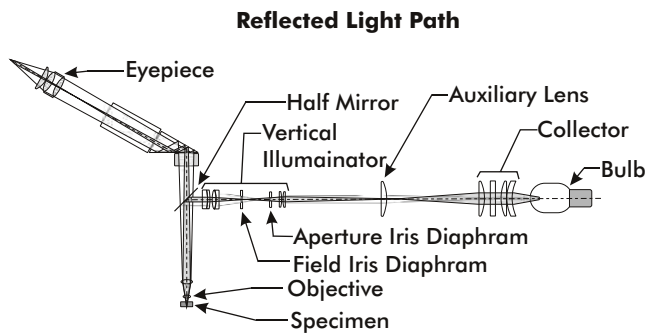

LIGHT SOURCES

Illumination is achieved from a point light source that is imaged directly on the specimen, giving a narrow intense beam. This is generally referred to as "critical illumination". The most suitable type is "Koehler Illumination", which includes a collecting or condensing lens and a field iris (diaphragm).

In this kind of illumination the collecting lens and the field iris directly control internal light. The image of the light source is focused at the aperture iris and not in the field of view. Therefore, uneven distribution of energy in the source does not result in uneven brightness. In some cases (with low power objectives), a ground glass filter is used to get more even distribution. Where high amounts of infrared rays are projected, heat-absorbing filters are used.

The following outline illustrates characteristics of some of the most common light sources.

Low voltage tungsten (12W to 100W)	1850°K to 3150°K	
AC/DC Carbon Arcs	3400°K to 3800°K (somewhat obsolete)	
Mercury Arc	} High Pressure Illuminators	All Spectral
Zirconium Arc		3100°K to 3200°K
Quartz Halogen		3000°K to 3200°K
Projection Bulb		2900°K to 3000°K
Xenon Arc		Approx. 6320°K

Color Temperature

Color temperature is a numerical expression for a certain relative spectral intensity distribution and is measured in degree Kelvin on the absolute temperature scale. It is not necessarily identical with the actual temperature of the lamp filament, but the temperature to which a so-called black body, an idealized thermal radiator, would have to be heated to emit light of the same relative spectral distribution.

Wavelength and N.A. The shorter the wavelength (color) of light, the higher the resolving power—as illustrated. Remember that the wavelengths are: Red (7000°A); Green (5700°A); and Blue (4000°A).

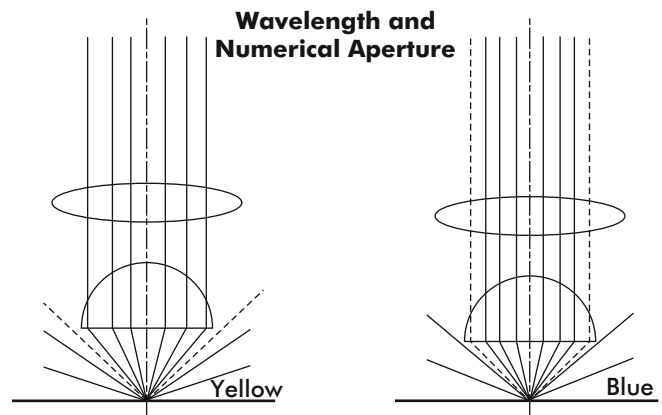

APERTURE IRIS

Rays or bundles of light emitted from a source pass through a collecting or condensing lens system. The rays furthest from the center are bent to converge closer to the center at a point very near to the aperture iris. In this way, most of the available rays pass through it.

This (usually) variable opening controls the amount of rays passing through it to the back lens of the objective. After a specimen is brought into focus one may remove the eyepiece and view the image of the aperture iris.

If one is checking centration, care should be exercised to avoid parallax. The proper setting of this iris is governed by the N.A. of the objective. When centered and properly set, it can be seen focused on the back lens of the objective just inside of the periphery of the lens. It should be understood that this is a critical setting and quite necessary if one is to achieve optimum performance from the objective. It determines the resolution and contrast of the primary or aerial image. Too small an opening will reduce the resolution and cause interference fringes, while too wide an opening will result in haziness over the entire field. This iris should not be used to control image brightness, which is the exclusive task of the lamp intensity control or filters.

Aperture Iris and N.A.

By opening the aperture diaphragm until the whole back lens of the objective is filled with light, the resolving power will be fully utilized. As previously stated, too small an opening will reduce resolution and cause interference fringes. Too wide an opening will cause haziness over the entire field.

We can now see that the resolving power of an objective is mainly determined by the N.A. and the wavelength of the illumination source, in addition to good corrections for aberrations. Simply expressed, it is the capacity of an optical system to separate very close lines so that each line can be seen distinctly.

Aperture Iris and Numerical Aperture

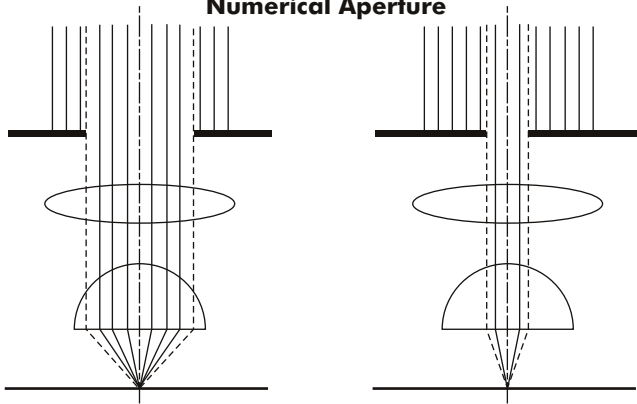

For example, an N.A. of 0.25 1000 lines/mm
 0.5 2000 lines/mm
 1.0 4000 lines/mm

Therefore any optical magnifications over 1500 may be considered empty, that is to say, devoid of resolving power.

FIELD IRIS

The rays of light leaving the aperture iris pass through a condensing lens and then enter the field iris. The purpose of this iris is to prevent glare that is caused by internal reflections. However, with the introduction of

coated lenses sometime around 1938, the internal glare problem was minimized.

Lens coating is accomplished by evaporating Lithium or Magnesium Fluoride or other suitable metallic salts in a high-vacuum system. The coating is usually one-quarter of a wavelength of light or four-millionths of an inch thick. To effectively minimize internal glare, all air-to-glass surfaces are coated. Coatings are very soft and so extreme care should be exercised when cleaning or removing lint.

In a properly aligned microscope with Koehler Illumination, the image of the field iris can be seen on the plane of the specimen when the specimen is in focus. The field iris should be stopped down to check centration and then opened just far enough to be clear of the field of view. In this way, any internal reflections fall out of the field of view. This procedure should be repeated when changing objective powers.

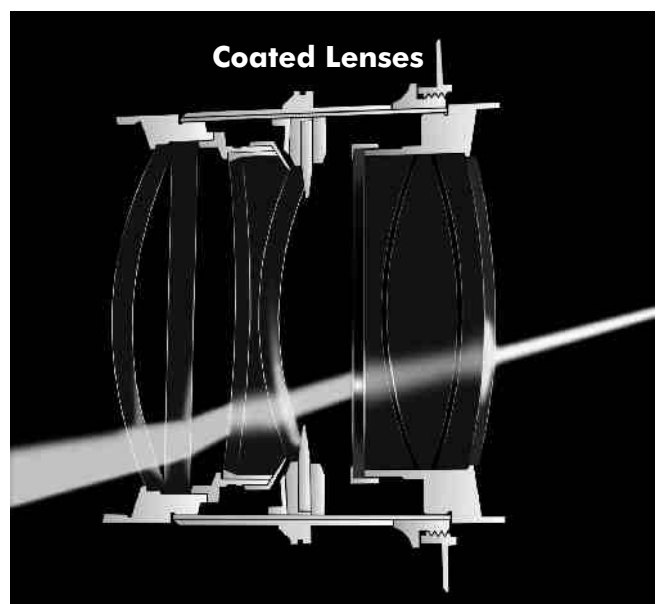
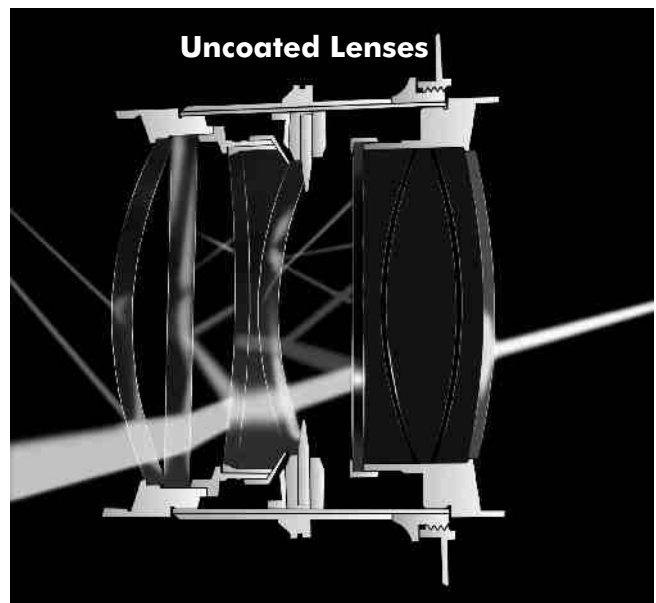

ABOUT THE EYE

Like any ordinary lens, the lens of the eye obeys a fundamental law of optics, which states: "An object, the image of that object, and the center of the lens must all lie on the same straight line". Unlike glass lenses (fixed focal length) the eye lens has the remarkable ability to change its focal length. It thereby brings into sharp focus (on the retina), the image of an object whose distance from the eye may range from infinity down to about 10 inches (250 mm). The inability of the eye to accommodate for distances shorter than 10 inches results in a limit to the size of retinal image. This limit is used as a reference to rate magnifiers and microscopes for magnifying power. Simply stated, an object magnified 100 times in a microscope will appear 100 times larger than if viewed at 10 inches by the eye.

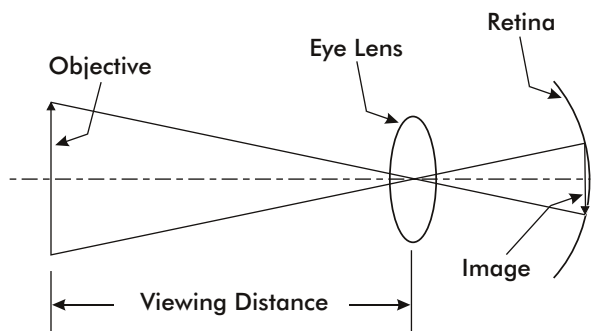

Light passing through the cornea traverses the "aqueous filling" or "humor". It passes through the pupil (the black circular orifice which is surrounded by the iris). The iris is able to expand and contract, altering the diameter of the pupil, and thereby providing a means of regulating the amount of light entering the interior of the eye. The blind spot occurs at the junction of the optic nerve and the retina and is due to the absence of light sensitive cells in this area.

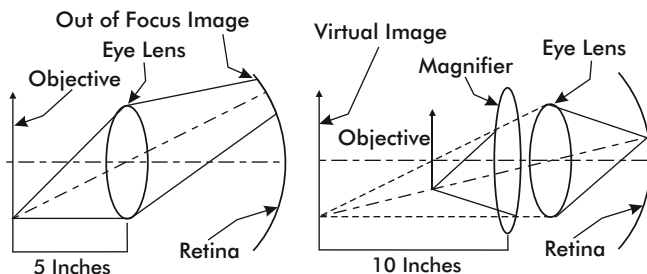

As illustrated, an object placed 5 inches from the eye lens is out of focus. If a 2X magnifier is placed between the object and the eye lens, the image will be in focus on the retina.

COMMON OVERSIGHTS

- Failure to properly align the light source
- Failure to check the aperture iris for centration
- Failure to set the aperture iris for the specific objective power
- Failure to set the field iris for the specific field of view
- Failure (where applicable) to center the objectives
- Failure to insert the proper photographic filter
- Dust, grease, or dirt on any of the air-to-glass surfaces
- Poorly etched samples
- Wrongly etched samples should be heavy for low magnification, light for high magnification
- Badly prepared samples

BIBLIOGRAPHY

A large portion of this paper was originally assembled by the writer in close collaboration with Mr. George W. Graves (deceased); a very competent leader and good friend; and from sales literature available from the following companies.

American Optical Company

Bausch & Lomb

Buehler Ltd.

Deer Island Lenses

E. Leitz Inc.

Olympus Corp. of America

Carl Zeiss (Oberkochen)

LECO Corporation

3000 Lakeview Avenue • St. Joseph, MI 49085-2396 • Phone: 800-292-6141 • Fax: 269-982-8977
info@leco.com • www.leco.com • ISO-9001 • No. FM 24045 • LECO is a registered trademark of LECO Corporation.